

SUNDS Cleaner

Cleaning of raw material

Three cornerstones for efficient chip wash:

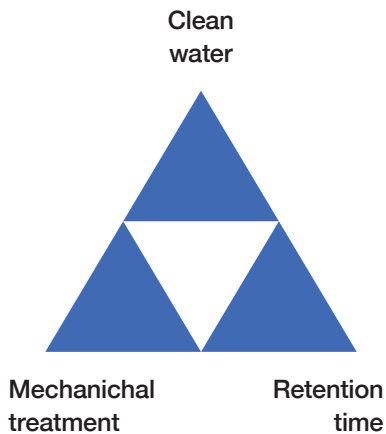

Chip washer system for cost efficient cleaning of raw material.

- Increased running time for critical performance equipment e.g segments, plug screws and refiner housing.
- Improved board quality due to lower grit content.
- **Option:** Integration with airCleanMAX to minimize the water usage.
- **Option:** High effective water cleaning system for maximum water recirculation and improved chip cleaning efficiency.

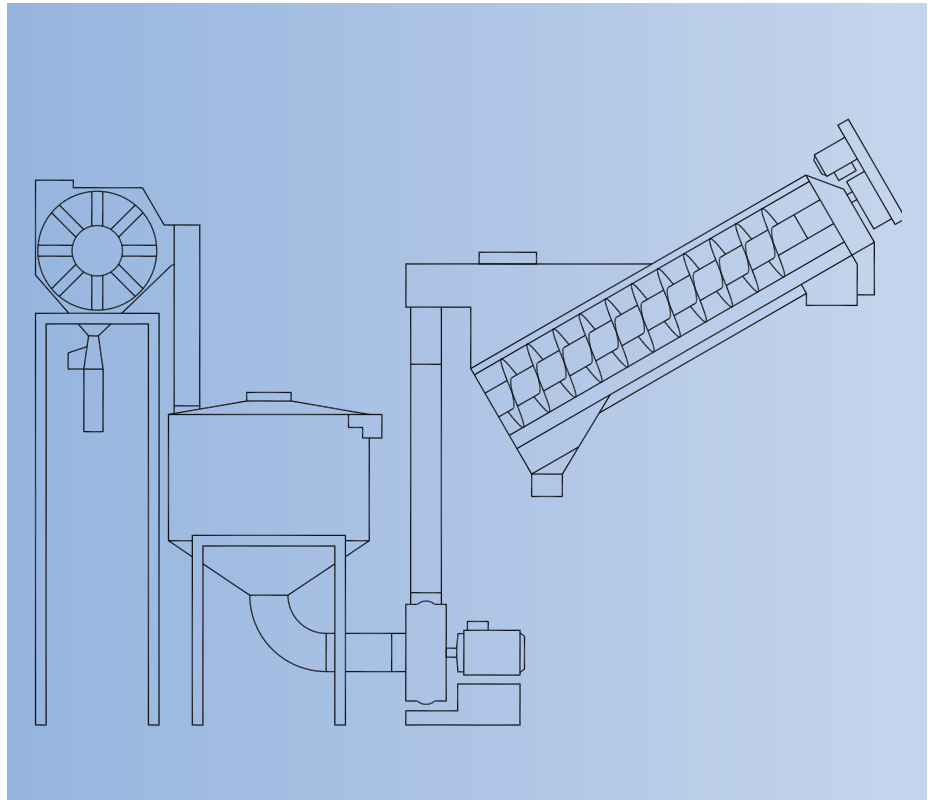

Key Equipment:

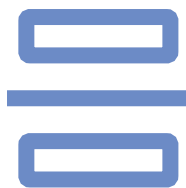

Chip separator



Chip drainer



Centrifuge

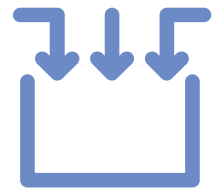

Water vessel